

User's Manual

dynadock™

Contents

Introduction	7
Features	8
Front panel	8
Back panel	9
Package contents	10
System Requirements	10
Assembly	11
Installation	13
Installing the Drivers	13
Connecting the dynadock™ to the Computer	21
Uninstalling	23
Uninstalling - Windows Vista® Operations	23
Uninstalling - Windows® XP Operations	25
Using the dynadock™	27
USB 2.0 Ports (Front and Back Panel)	27
Ethernet Port (Back Panel)	27
Serial Port (Back Panel)	28
Front Panel Audio Port (Microphone)	29
Front Panel Audio Port (Headphones or Speakers)	29
Video Port (VGA or DVI)	33
How Standby/Sleep or Hibernate Mode Affects Devices Attached to the dynadock™	39
Disconnecting the dynadock™	40
Eject Dock	40
Eject Dock and Sleep	41
Eject by use of command line	42
Removing Settings	42
Select Audio Device	45
Specifications	46

Regulatory Compliance

FCC Information

Product Name: *dynadock™*

Model number: *PA3541*, PA3542**

FCC notice “Declaration of Conformity Information”

This equipment has been tested and found to comply with the limits for a Class B digital device, pursuant to part 15 of the FCC rules. These limits are designed to provide reasonable protection against harmful interference in a residential installation. This equipment generates, uses and can radiate radio frequency energy and, if not installed and used in accordance with the instructions, may cause harmful interference to radio communications. However, there is no guarantee that interference will not occur in a particular installation. If this equipment does cause harmful interference to radio or television reception, which can be determined by turning the equipment off and on, the user is encouraged to try to correct the interference by one or more of the following measures:

- Reorient or relocate the receiving antenna.
- Increase the separation between the equipment and receiver.
- Connect the equipment into an outlet on a circuit different from that to which the receiver is connected.
- Consult the dealer or an experienced radio/TV technician for help.



WARNING: *Changes or modifications made to this equipment, not expressly approved by TOSHIBA or parties authorized by TOSHIBA could void the user's authority to operate the equipment.*

FCC Conditions

This equipment has been tested and found to comply with Part 15 of the FCC Rules. Operation is subject to the following two conditions:

- (1) This device may not cause harmful interference
- (2) This device must accept any interference received. Including interference that may cause undesired operation.

Contact

Address: TOSHIBA America Information Systems, Inc.
9740 Irvine Boulevard
Irvine, California 92618-1697

Telephone: (949) 583-3000

EU Declaration of Conformity

TOSHIBA declares, this product conforms to the following Standards:

Supplementary Information: “This product complies with the requirements of the EMC Directive 89/336/EEC and/or the Low Voltage Directive 73/23/EEC.”

This product is carrying the CE-Mark in accordance with the related European Directives. The party responsible for CE-Marking is TOSHIBA Europe GmbH, Hammfelddamm 8, 41460 Neuss, Germany.

WEEE Information

For EU (European Union) member users: According to the WEEE (Waste electrical and electronic equipment) Directive, do not dispose of this product as household waste or commercial waste. Waste electrical and electronic equipment should be appropriately collected and recycled as required by practices established for your country. For information on recycling of this product, please contact your local authorities, your household waste disposal service or the shop where you purchased the product.



Safety Instructions

Always read the safety instructions carefully:

- Keep this User's Manual for future reference
- Keep this equipment away from humidity
- If any of the following situations arise, get the equipment checked by a service technician:
 - The equipment has been exposed to moisture.
 - The equipment has been dropped and damaged.
 - The equipment has obvious sign of breakage.
 - The equipment has not been working well or you cannot get it to work according to the User's Manual.

Copyright Statement

No part of this publication may be reproduced in any form by any means without the prior written permission. Other trademarks or brand names mentioned herein are trademarks or registered trademarks of their respective companies.

Disclaimer

Information in this document is subject to change without notice. The manufacturer does not make any representations or warranties (implied or otherwise) regarding the accuracy and completeness of this document and shall in no event be liable for any loss of profit or any commercial damage, including but not limited to special, incidental, consequential, or other damage.

July 2007, Rev3.0

Trademarks

Intel, Intel Core, Pentium and Celeron are trademarks or registered trademarks of Intel Corporation.

Microsoft, Microsoft Office, Windows and Windows Vista are either registered trademarks or trademarks of Microsoft Corporation in the United States and/or other countries.

AMD, AMD K6, Athlon and Duron are registered trademarks or trademarks of Advanced Micro Devices Incorporated.

Ethernet is a registered trademark and Fast Ethernet is a trademark of Xerox Corporation.

Adobe and Reader are either registered trademarks or trademarks of Adobe Systems Incorporated in the United States and/or other countries.

Other trademarks and registered trademarks not listed above may be used in this manual.

Precautions

The Fn + F5 functionality detailed in the electronic User's Guide for your TOSHIBA computer only controls the internal video controller of your computer.

The TOSHIBA dynadock utilizes an advanced video graphics controller to display the video on the external monitor connected to it. However, due to USB 2.0 transfer speed limitations, some or all portions of DVD playback may appear slow or choppy. This is not a malfunction of the dynadock. Move the video playback from the external monitor to your computer display for optimal video performance when viewing DVDs.

The playback of DVD is not supported in the mirror mode.

The 3D screensavers (3D FlowerBox and so on) do not work in either mirror or extended mode.

This product does not support 3D programs.

Unable to enter full screen DOS mode in the mirror mode.

Google Earth does not work in the mirror mode.

The video driver passes 24-bit data to the device if you have selected 32-bit color quality. This is for more efficient data transfer.

When recording audio, it is recommended that you manually configure the microphone volume settings.

Precautions for Windows Vista® only

When the dynadock is connected, the screens of your computer and external device will become BASIC mode automatically. The screen of your computer will return to AERO™ mode automatically when the dynadock is disconnected.

The games in OpenGL such as Quake3 will not be supported in the mirror mode. If you want to play these kinds of games, we suggest you disconnect the dynadock.

USB, CPU resources and other devices may be affected when playing movies or transferring large amounts of data via the dynadock.

The sound may be distorted or delayed when you play MIDI/MPG files. If it's a MIDI file, please try to change your media player visualization settings. If it's a MPG file, we suggest you play it without connecting the dynadock.

Introduction

The Toshiba dynadock with Video utilizes a single USB port to extend your computer to your desktop environment with one easy connection, enabling you to connect all of your peripherals, including six USB devices, Ethernet network, serial device, headphones, speakers and microphone plus an external monitor and digital audio equipment. It is ideal for computers that have many connectivity demands.

The upright slim design of the dynadock saves your desktop space while the two USB ports on the front panel give you easy accessibility. The dynadock is hot swappable; you can add or remove any device without rebooting the computer. With all these features, the dynadock is a perfect accessory whether you are at home or at the office.

With the video port, your computer can be connected to an external monitor, LCD or projector at native display resolutions of up to 1600 x 1200 pixels (DVI version only). The connected monitor can be configured to either mirror your primary screen or extend the Windows® desktop allowing visibility of more applications at the same time. No more stacking windows within the confines of a single display.

An additional feature is the S/PDIF digital audio output. It directly outputs the digital sound source from the computer to your home audio receiver without the loss of high quality sound. If you are using 2 channel speakers or headphones via the conventional audio port, you can still enjoy the 7.1 surround sound, which is achieved by the virtual multi-channel audio function.



NOTE: The dynadock is available in two video support versions, either a VGA video port or a DVI video port. This user manual contains information for both versions of the dynadock. Please pay attention to and follow the instructions for the version you have. For more information and software upgrades please visit www.dynadock.com.

Features

- Single USB plug connecting to your computer
- Upright slim design saves desktop space
- Easily accessible ports located on the front
- Supports notebook-quality video on external monitor
 - VGA resolution up to SXGA (1280 x 1024), 16/32-bit color
 - DVI resolution up to UXGA (1600 x 1200), 16/32-bit color
- Hot swappable; add or remove devices without rebooting the computer
- Virtual 7.1 channel surround sound
- All video and audio drivers included
- Provides TOSHIBA dynadock Utility to remove all the devices at one time
- Power is always provided by the front USB ports, even though the computer is off

Front panel

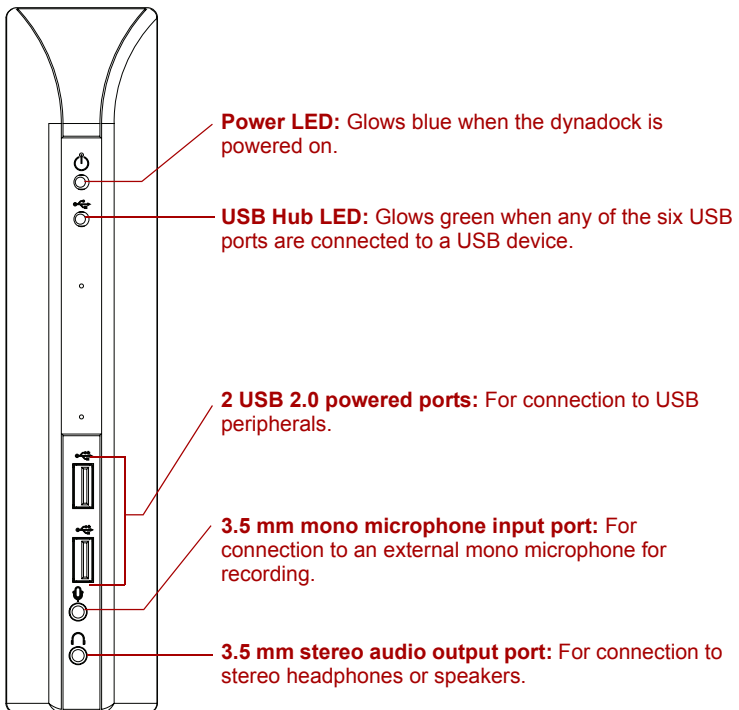

(Sample Illustration) Indicators and connectors on the front of the dynadock

Back panel

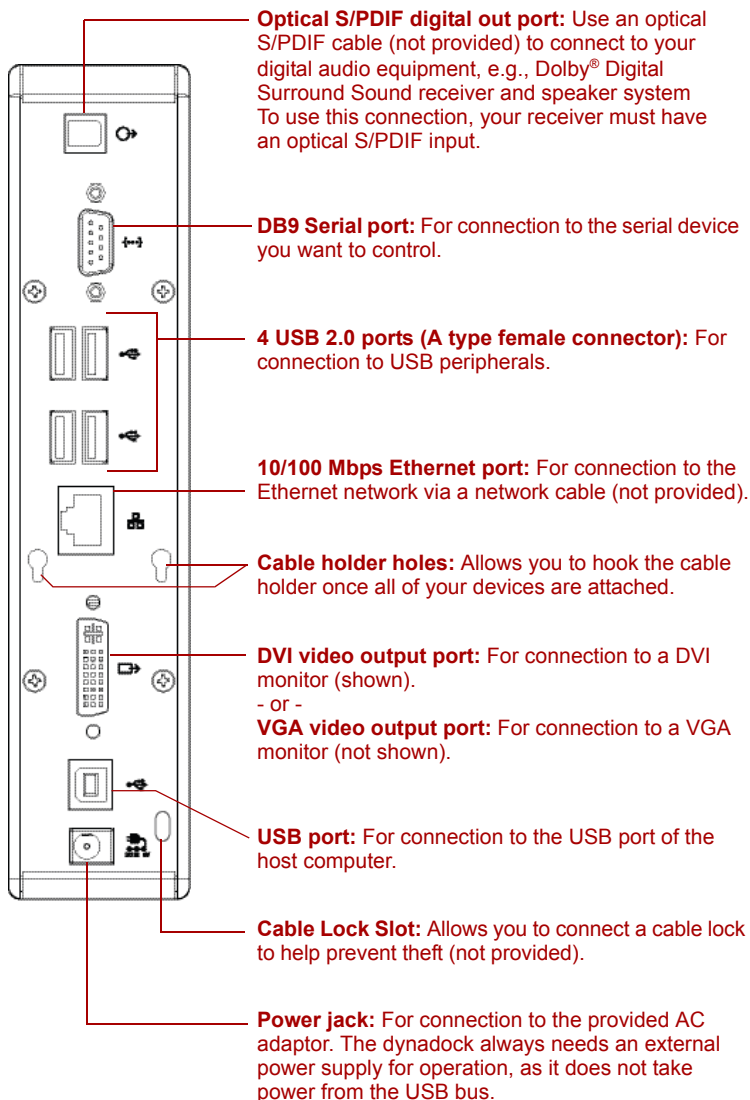

(Sample Illustration) Connections on the back of the dynadock

Package contents

- dynadock™ (VGA or DVI video interface)
- Base plate
- Cable Holder
- USB 2.0 Cable
- AC Power Adaptor
- AC Power Cord/cable
- CD (User Manual, Driver and Utility)
- Quick Installation Guide
- DVI to VGA video adapter (DVI version only)

System Requirements

- 1.2GHz or higher processor. Intel® Pentium®/Celeron® family, or AMD K6®/AMD Athlon™/AMD Duron™ family, or compatible processor recommended (Intel® Core™ 2 Duo 2.0 GB or higher processor recommended for optimal video performance)
- 512 MB memory or higher (1 GB memory or higher recommended)
- USB 2.0 port
- 30 MB of available disk space
- Windows® XP with SP2/Windows Vista® (32-bit edition)
- For optimal results the display resolution should be configured to 800 x 600 with 16-bit color.

Assembly

Remove the base and dynadock from the packaging. You will need to assemble the two pieces.

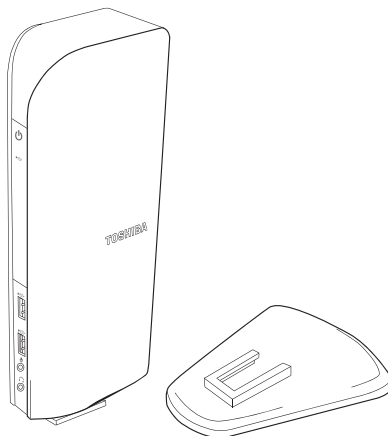

(Sample Illustration) The dynadock and base before assembly

Slide the dynadock onto the base as shown below.

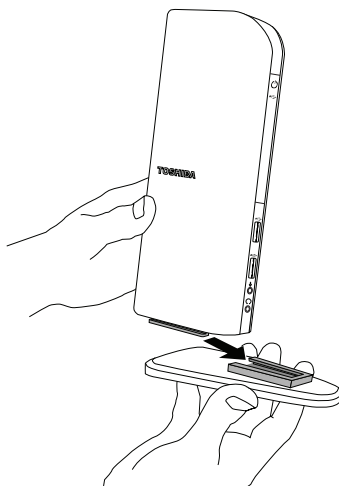

(Sample Illustration) Assembling the dynadock and base

When assembled, the dynadock is a self-standing, easy to place unit.

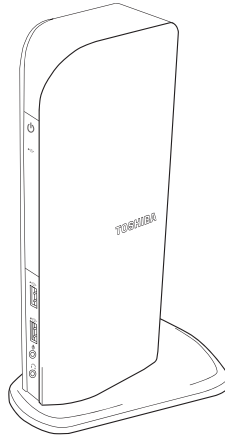

(Sample Illustration) The assembled dynadock™

Installation

Installing the Drivers



NOTE: The following installation steps are for both Windows Vista® and Windows® XP operating systems. Although most steps are similar, there are some differences between the two operating systems so please follow the steps for your operating system where indicated.

1. Insert the provided Installation CD into your optical disc drive. It will run automatically and the dialog box will appear.

If the auto-run function is disabled on your system, the program will fail to load automatically. Please open the disk in Windows® Explorer, and double click "AutoRun.exe".



(Sample Illustration) Initial Screen

- Click on “Install dynadock Utility & Driver”, the program will begin installing the dynadock Utility and all drivers necessary for the dynadock device. Follow the screen directions to finish the utility installation.

Step 1: When the welcome screen appears, click **Next**.

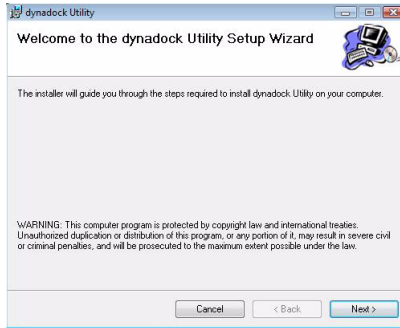

(Sample Image) Welcome screen

Step 2: Select “I Agree” and click **Next**.

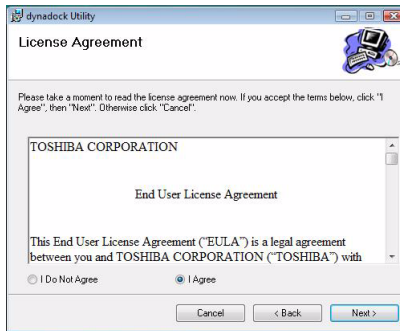

(Sample Illustration) License Agreement screen

Step 3: Choose the destination folder.



(Sample Image) Choose Destination Location screen

Step 4: Click **Next** to start the installation. This may take several minutes.

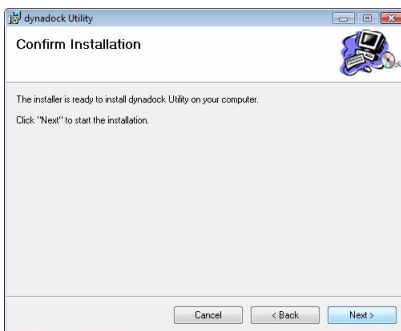

(Sample Image) Ready to Install screen

Step 5: Click **Close** when the “Installation Complete” dialog box shown below appears.

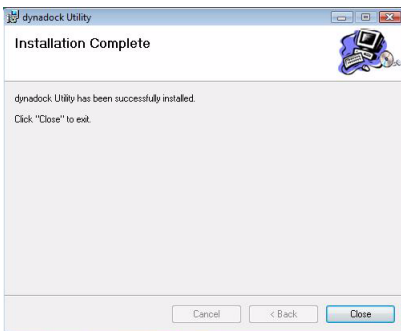

(Sample Image) Finish screen



NOTE: There are slight differences in the installation between Windows® Vista® and Windows® XP. Please follow the steps for your operating system.

Windows® Vista® Operations:

3. After the utility installation is completed, the “Video” driver will be installed.

Step 1: When the welcome screen appears, click **Next**.

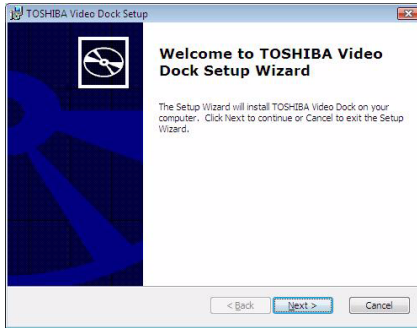

(Sample Image) Welcome screen

Step 2: Select “I accept the terms in the License Agreement” and click **Next**.

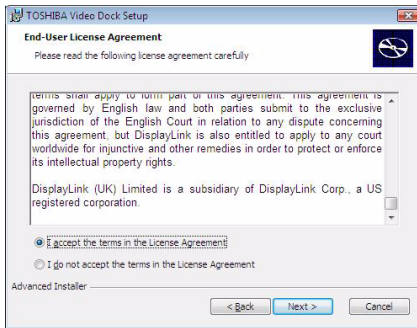

(Sample Illustration) License Agreement screen

Step 3: Click **Install** to start the installation. This may take several minutes.

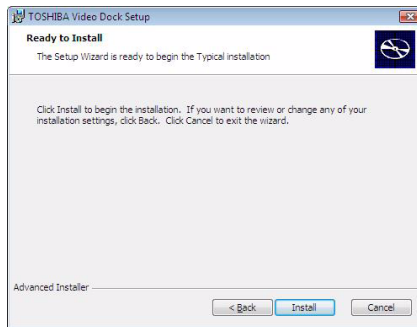

(Sample Image) Ready to Install screen

Step 4: Click **Finish** when the dialog box shown below appears.

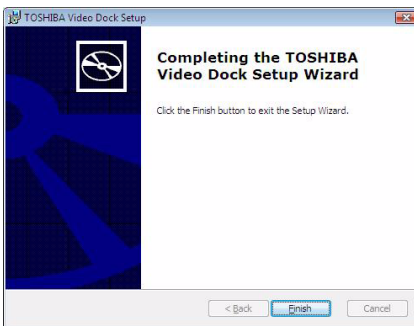

(Sample Image) Finish screen

4. Once the video drivers are installed, the "Audio" driver will be installed automatically. This step requires the dynadock to be connected to your computer. If the dynadock is not detected, the following message will appear. Please connect the dynadock to your computer and click **Retry** to proceed. For detailed information on how to connect the dynadock, please refer to [Connecting the dynadock™ to the Computer](#) section of this manual.

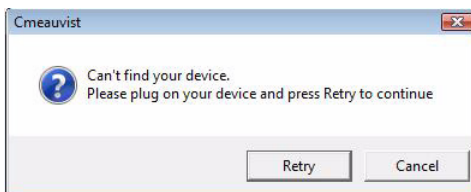

(Sample Image) Not detected the dynadock screen

5. After finishing the installation, the program will request you to restart the computer. Choose "Yes" and click **OK** to finish the setup. All devices will take effect after restarting.

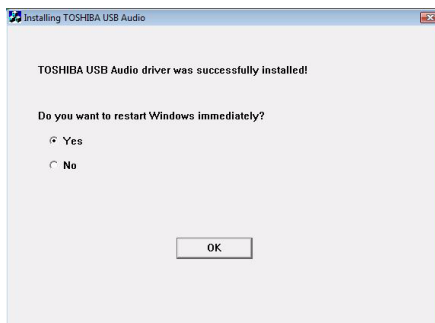

(Sample Image) Restart computer screen



NOTE: This completes the installation for systems with Windows Vista®.

Windows® XP Operations:

3. After the utility installation is completed, the “Video” driver will be installed automatically.

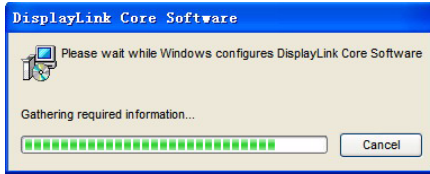

(Sample Image) Video driver Install screen



NOTE: During the installation, the screen will flicker a couple of times. This is normal. A dialog box may prompt to restart the computer. Please do not restart at this time in order to install additional drivers.

4. Once the video drivers are installed, a message will prompt you to install the “Audio” driver. This step requires the dynadock to be connected to your computer. Please connect the dynadock to your computer and click **RETRY** to proceed. For detailed information on how to connect the dynadock, please refer to [Connecting the dynadock™ to the Computer](#) section.

If the dynadock is not detected, the message will appear again. Please make sure the dynadock is connected correctly.

If you click **Cancel**, the program will exit the installation of the audio driver.

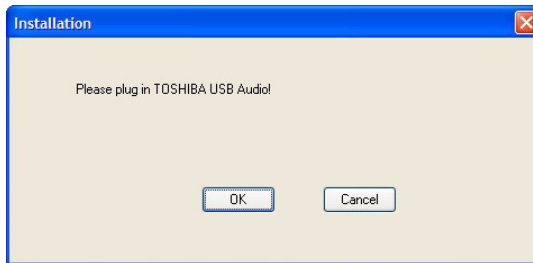

(Sample Image) Not detected the dynadock screen



NOTE: Installation of the “Audio” driver will fail if the dynadock is not connected to the PC.

5. Install drivers.

Follow the screen directions to finish the driver installation.

Step 1: When the welcome screen appears, click **Next**.

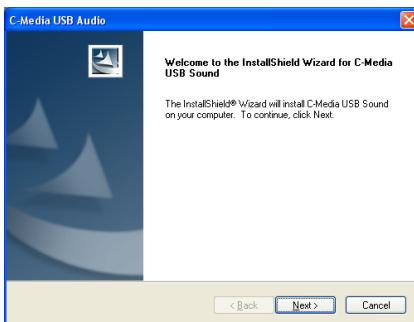

(Sample Image) Setting selection screen

Step 2: Choose a destination location for the installation or just use the default location. Then click **Next**.

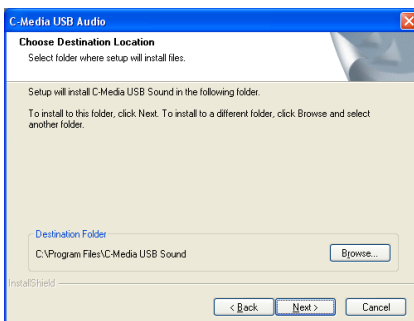

(Sample Image) Choose Destination Location screen

Step 3: Click **Next** to start copying the program files to your computer. This step may take a few minutes to install.

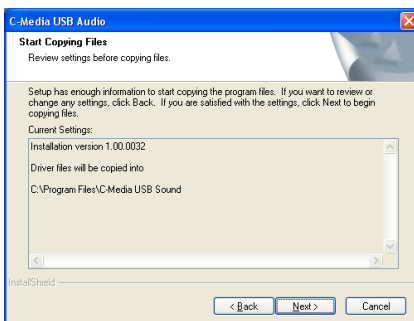

(Sample Image) Installation files copying screen

6. After finishing the installation, the program will request that you restart the computer. Choose “Yes, I want to restart my computer now” and click **Finish** to finish the setup. All devices will take effect after restarting.

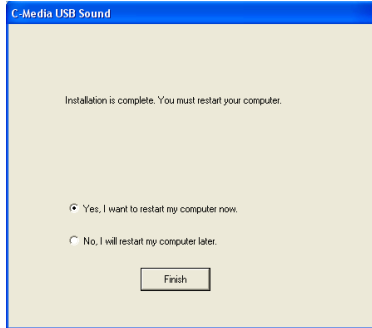

(Sample Image) Restart computer screen



NOTE: This completes the installation for computers with Windows® XP operating system.

Background Utility Program

After the dynadock utility is installed, a program named ‘TOSHIBASvr.exe’ will run automatically in the background. It can be viewed in the Windows Task Manager. The program can detect the insertion and removal of the dynadock.



NOTE: The utility program does not impact any other programs on your PC. Please do not turn it off.

Connecting the dynadock™ to the Computer

It is recommended to connect the dynadock to your PC according to the instructions during the audio driver installation. Please follow the steps to connect it correctly:

1. Plug the AC adaptor into the DC-IN on the back of the dynadock.

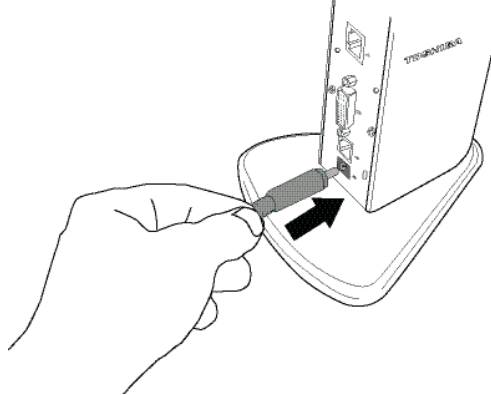

(Sample Illustration) Connecting the power to the dynadock

2. Connect the AC adaptor with the power cord/cable, and then connect the power cord/cable to a live electrical outlet. The power indicator on the front panel glows blue when the dynadock is powered on.
3. Plug the square end of the USB cable into the USB upstream connector on the back of the dynadock.

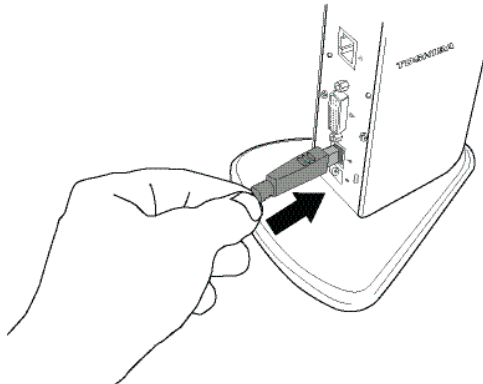

(Sample Illustration) Connecting the USB cable to the dynadock

4. Plug the other end of the USB cable into an available USB 2.0 port on your computer.

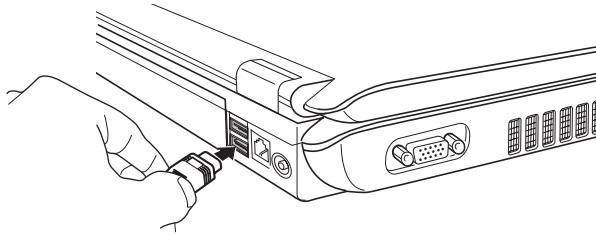

(Sample Illustration) Connecting the USB cable to your computer



NOTE: Be sure to remember which USB port is used for the driver installation and always plug the dynadock into the same USB port, otherwise the Windows® operating system will treat the dynadock as a new device and ask to install the drivers again. Only one dynadock can be operated on one PC at a time.

Uninstalling

To remove the dynadock Utility and all the drivers from your computer, please follow the following procedures to remove the Utility, the Video driver and the Audio driver one by one.

Uninstalling - Windows Vista® Operations

Uninstalling the Utility

1. To remove the dynadock utility from your computer, open **Uninstall a program** from the **Control Panel**. Choose “dynadock Utility” from the list, and click the **Uninstall** button.

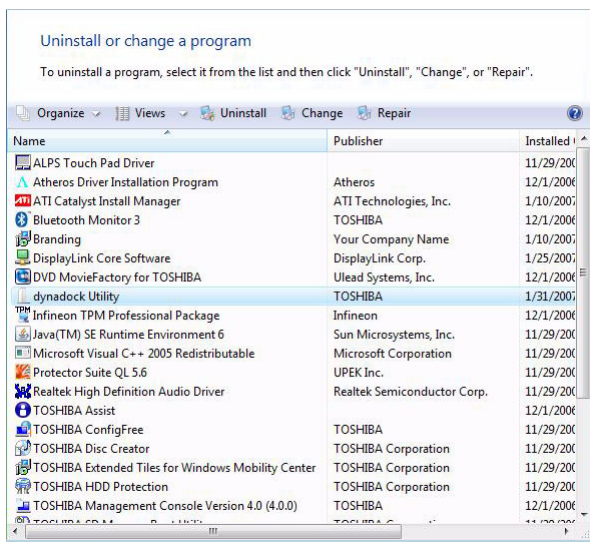

(Sample Illustration) Uninstall the program

2. Follow the screen directions to finish the uninstalling.

Uninstalling the Video Driver

1. To remove the Video driver completely, open **Uninstall a program** from the **Control Panel**, then choose “TOSHIBA Video Dock” and click the **Uninstall** button.

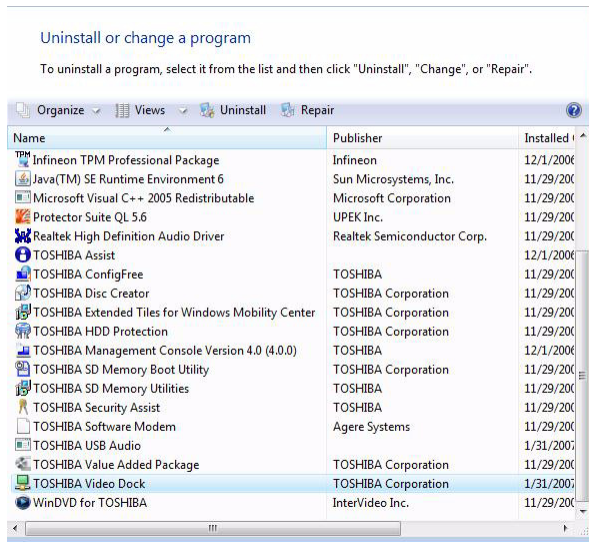

(Sample Illustration) Uninstall TOSHIBA Video Dock

2. Follow the screen directions to finish the uninstalling.

Uninstall the Audio Driver

1. To remove the Audio driver completely, open **Uninstall a program** from the **Control Panel**, then choose “TOSHIBA USB Audio” and click the **Uninstall/Change** button.

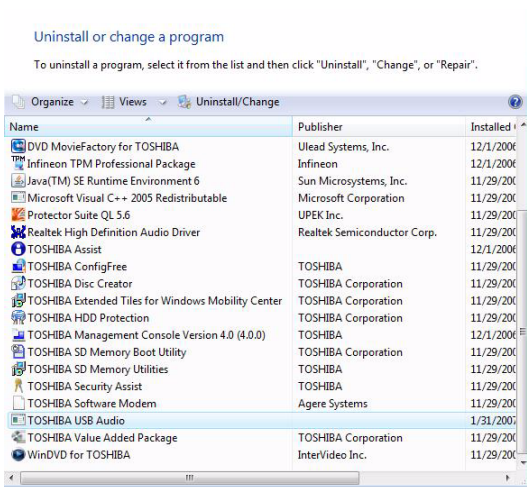

(Sample Illustration) Uninstall TOSHIBA USB Audio

2. Follow the screen directions to finish the uninstalling.

Uninstalling - Windows® XP Operations

Uninstalling the Utility

1. To remove the dynadock utility from your computer, open **Add/Remove Programs** from the **Control Panel**. Choose “dynadock Utility” from the list, and click the **Remove** button.

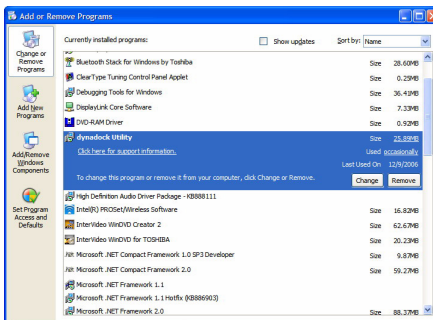

(Sample Illustration) Remove the program

2. Follow the screen directions to finish the uninstalling.

Uninstalling the Video Driver

1. To remove the Video driver completely, please open **Add/Remove Programs** from the **Control Panel**, then choose “TOSHIBA Video Dock” and click the **Remove** button.

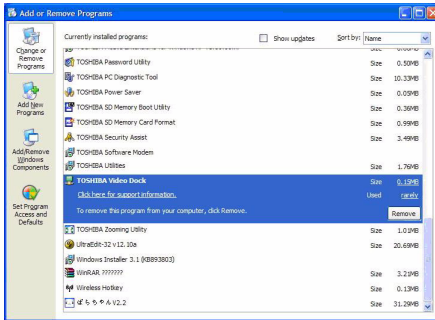

(Sample Illustration) Remove TOSHIBA Video Dock

2. Follow the screen directions to finish the uninstalling.

Uninstall the Audio Driver

1. To remove the Audio driver completely, please open **Add/Remove Programs** from the **Control Panel**, then choose “TOSHIBA USB Audio” and click the **Change/Remove** button.

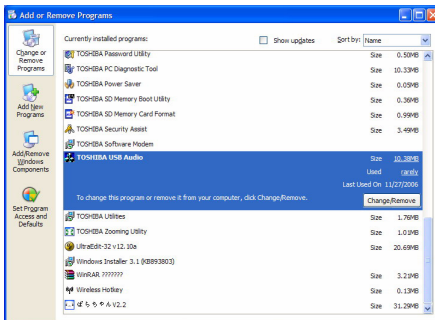

(Sample Illustration) Remove TOSHIBA USB Audio

2. Follow the screen directions to finish the uninstalling.

Using the dynadock™

You may connect devices to the appropriate ports on the dynadock while your computer is running. A slight delay and display flickering is normal before the computer recognizes the new device. Please be patient.

USB 2.0 Ports (Front and Back Panel)

Connect any USB device to one of the dynadock's six USB ports.

- When no device is connected to the port, the indicator light is off.
- If a device is connected to the port and the connection works properly, the indicator light glows green (on).
- If your USB device, such as a printer or optical drive, etc., came with its own AC adaptor, make sure that it is plugged into the device and a live electrical outlet.



NOTE: Only the front two USB ports provide power when the computer is either off, suspended or disconnected.

Ethernet Port (Back Panel)

Connect one end of a network cable (not provided) to the Ethernet port (RJ-45) on the dynadock and the other end to your network for high performance network access. To configure the network properties of the Ethernet adapter:

In Windows Vista®, select **Start > Control Panel > View network status and tasks > Manage network connections**.

In Windows® XP, select **Start > Settings > Network Connections**.

In the **Network Connections** folder, double-click the connection icon for the dynadock's Ethernet adapter, which is indicated by **ASIX AX88772 USB2.0 to Fast Ethernet Adapter**.



(Sample Image) Network Connection icon

This will open the **Local Area Connection Properties** window for you to configure the network settings as required according to your network environment. If you are unsure about the settings, consult your network administrator for assistance.

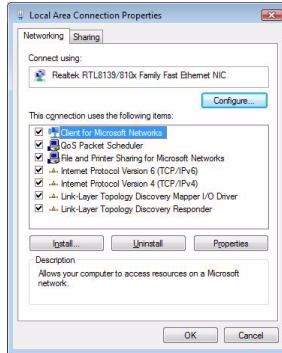

(Sample Image) Local Area Connection Properties



NOTE: The LAN port does not support Wake-On-LAN.

Serial Port (Back Panel)

To connect a serial device, attach the serial cable (not provided) to the serial port on the dynadock and your serial device. Then install the software driver according to the instructions that come with the device. When prompted to select the port, choose COMx, where x is the COM port number assigned by your operating system.

To see the COM port number assigned by your operating system:

1. In Windows Vista®, please open **Manage** by right-clicking **Computer** and select **Device Manager**.

In Windows® XP, please open **Device Manager** by right-clicking **My Computer** and select **Properties**. Then click **Hardware > Device Manager**.

2. Under the **Ports (COM & LPT)** group, you should be able to find **Prolific USB-to-Serial Comm Port**. The com port number will appear next to the string.

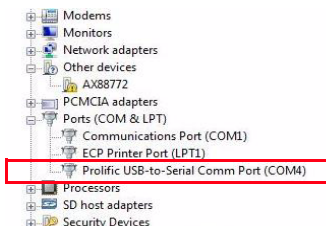

(Sample Image) Locating the Serial Comm Port

Front Panel Audio Port (Microphone)

To connect a microphone, plug the 3.5 mm mono microphone jack into the microphone input port.

Front Panel Audio Port (Headphones or Speakers)

After installing the provided audio software, a **USB 3D 106 Sound Configuration** utility is installed in your computer. It can be accessed by double-clicking the **USB 3D 106 Sound Configuration** icon on the system tray.



(Sample Image) USB 3D 106 Sound Configuration



NOTE: If the audio software has been properly installed and the icon is not on the system tray, it means the dynadock is connected to a different USB port from the one originally connected for installation. Re-plug the dynadock into the original USB port and the icon will appear again.

The utility comes with a friendly graphic user interface to optimize your audio effects. Most of the settings can be adjusted using the available sliders, images or buttons. Just make the adjustments to suit your personal preferences.

Using Virtual 7.1CH Function on 2CH Speakers/headphones

The audio output port on the front panel is used to connect stereo speakers or headphones. Although 2CH speakers may be connected, a virtual 7.1CH surround sound experience is possible using the software's virtual multi-channel function.

To enable the virtual 7.1CH audio function on 2CH speakers or headphones:

1. In the **Analog Output** section, select **headphone** (or the **headphone** icon in Windows® XP).

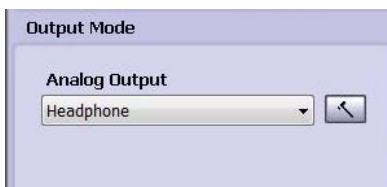

Windows Vista®



Windows® XP

(Sample Image) Select headphone

2. On the panel, click the **7.1 Virtual SPEAKER SHIFTER** button to enable the virtual multi-channel function.



(Sample Image) 7.1 Virtual SPEAKER SHIFTER button

3. The button next to **DSP Mode** string allows you to switch between the **SHIFTER** control and basic control window.

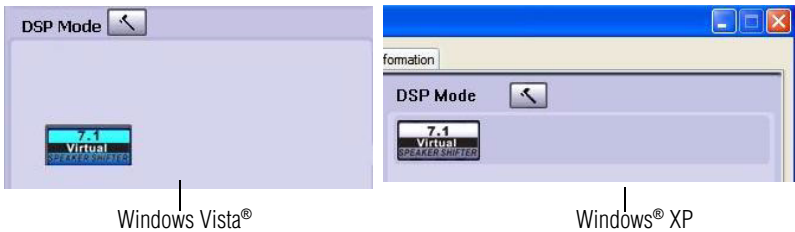

(Sample Image) DSP button

Launch the **USB 3D 106 Sound Configuration** utility from the System Tray. Click on the **Virtual Speaker Shifter** button to open the Shifter controls.

Using the Virtual Speaker Shifter Controls

1. Volume control
2. Rotate all the virtual speakers clockwise
3. Rotate all the virtual speakers counterclockwise
4. Manually rotate all the virtual speakers
5. Manual shifting function. You can drag a specific virtual speaker to the preferred position to enhance an individual channel output. For example, a low-volume center (for dialog) can be enhanced by being dragged closer to you

6. Reset the speakers to default settings

*(Sample Image) Shifter Controls***Using the Basic Controls**

1. To adjust/reset the volume of the left and right channel of your speakers/headphones
2. To test the left and right channel of your speakers/headphones

3. Stops the audio test

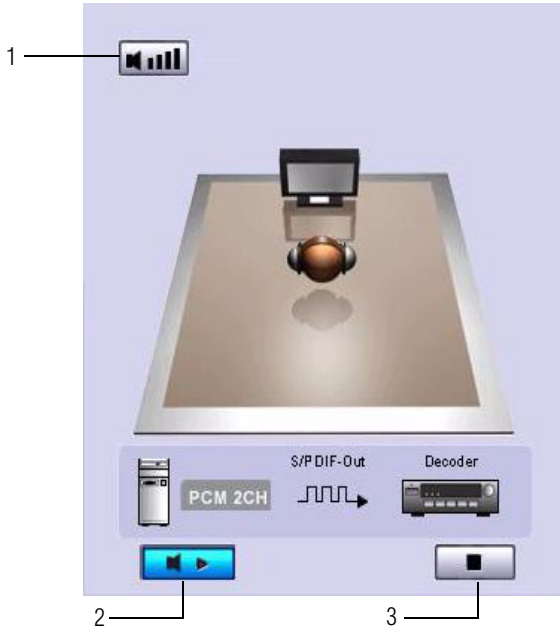

(Sample Image) Basic controls screen



NOTE: This can only be seen in Windows® XP.

Digital S/PDIF Output (Back panel)

Using the S/PDIF output function you can directly output the digital sound source from the computer to your home theater equipment without loss of sound quality.

To experience true digital sound quality:

1. Make sure your DVD content supports Dolby® Digital or DTS format.
2. Make sure your external decoder/AV receiver that connects to the dynadock supports Dolby® Digital or DTS decoding capability.

- Turn on the S/PDIF function in the **USB 3D 106 Sound Configuration** utility.
On the **Main Setting** tab of the utility, click the button next to the **S/PDIF Output** string and select **Digital Audio 48KHz** from the drop-down menu.

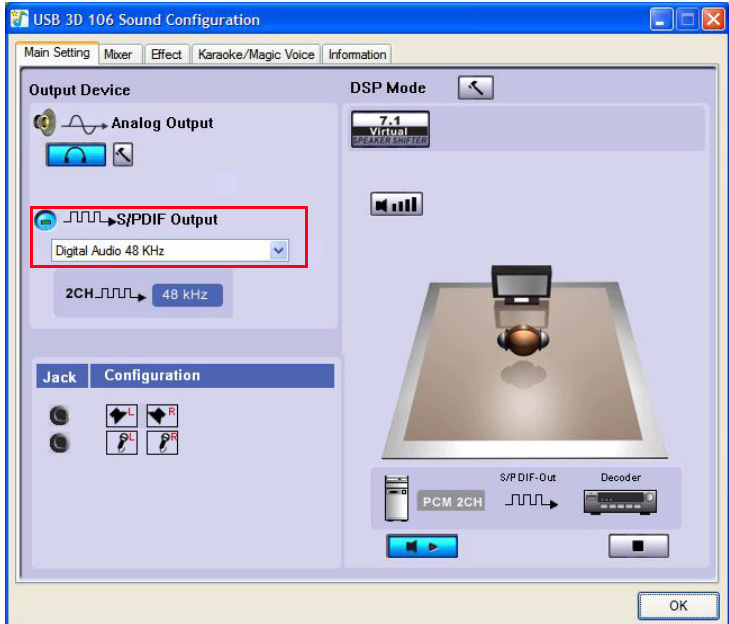

(Sample Image) S/PDIF selection

- Configure the **Audio Output** setting of your DVD playback software to use S/PDIF. (Access the software's setup or configuration panel to locate the Audio Out item).



NOTE: The above steps are for Windows® XP only. In order to use the S/PDIF function in Windows Vista®, select **Start > Control Panel > Hardware and Sound > Sound**. In the **Playback** tab, set the **Digital Output** as default device.

Video Port (VGA or DVI)

Connection

The dynadock is available in two versions:

VGA – for connection to VGA interface monitors

DVI – for connection to DVI interface monitors

The DVI version of the dynadock includes a DVI to VGA adapter to connect to a VGA monitor.

Although the ports and video drivers are different, the connection and setup is the same.

Connect the monitor cable (not provided) to the video output port on the dynadock and the external monitor. This cable can be connected and disconnected any time without disconnecting the dynadock from the USB port on your computer.



NOTE: *The dynadock should be connected to a USB 2.0 port for optimal video performance. The dynadock will work connected to a USB1.1 port, however video performance will be compromised. The USB connector may be plugged and unplugged while the dynadock is on.*

You can adjust video settings to customize your use of the dynadock with video. See [Adjusting Video Settings](#) for more information.

If the video output of the dynadock does not work once the dynadock is properly connected to an external monitor, the video (USB-VGA or USB-DVI) driver has probably not been installed correctly. Please make sure the driver is installed correctly by referring to the [Installing the Drivers](#) section.

Viewable screens

The dynadock video drivers give you the option of viewing a total of three screens.

1. The screen on the notebook,
2. External monitor connected to the video port on the notebook (if available)
3. External monitor connected to the dynadock



NOTE: *The external monitor connected to the dynadock may be identified as either “2” or “3” on the Windows Display Properties screen (depending on your model) although there may not be a total of 3 screens connected.*

Video Modes

The dynadock video output works in two modes:

- Mirror Mode
- Extended Mode

Mirror Mode

This mode “mirrors”—creates an identical display – from your computer screen to the external monitor. This is useful, for example, if you want to use a larger desktop monitor rather than the computer screen. In Mirror Mode, the dynadock automatically selects the settings (screen resolution, color quality and refresh rate) for the external monitor that will allow the best resolution based on your computer’s settings.

By default, the dynadock uses video output in Mirror Mode.

Extended Mode

Extended Mode lets you split your display across multiple monitors. This provides a number of advantages to increase productivity:

- View your large spreadsheets across two or three screens with display continuity.
- Multitask more effectively without overlapping windows
- Compare two documents simultaneously across two/three screens
- View videos/TV on one screen and reviews on the other

Set up the dynadock for Extended Mode - Windows Vista® Operations:

1. Position the mouse anywhere on your computer Desktop, right-click and select **Personalize**. The **Personalize appearance and sounds** screen will pop up.
2. On the **Personalize appearance and sounds** screen, click **Display Settings**. The **Display Settings** screen will pop up.
3. On the **Display Settings** screen, click the **Monitor** tab. In the pull-down menu, select the option containing **TOSHIBA Video Dock**.
4. Check the **Extend the desktop onto this monitor** box.
5. Drag the monitor icons (1,2 or 3) in the window at the top of the screen to match the physical arrangement of your computer screen and external monitor.
6. Click **OK** to close the Display Settings screen.

Set up the dynadock for Extended Mode - Windows® XP Operations:

1. Position the mouse anywhere on your computer Desktop, right-click and select **Properties**. The **Display Properties** screen will pop up.
2. On the **Display Properties** screen, click the **Settings** tab. In the **Display** pull-down menu, select the option containing **TOSHIBA Video Dock**.
3. Check the **Extend my windows desktop onto this monitor** box.
4. Drag the monitor icons (1,2 or 3) in the window at the top of the screen to match the physical arrangement of your computer screen and external monitor.

5. Click **OK** to close the **Display Properties** screen.



Windows Vista®



Windows® XP

(Sample Image) Display Properties screen



NOTE: Monitor “2” will also need to be configured for extended mode in order to use three monitors together in extended mode.

Switching from Extended Mode to Mirror Mode

Follow these steps to change the video output to Mirror Mode.:

Windows Vista® Operations:

1. Position the mouse anywhere on your computer Desktop, right-click and select **Personalize**. The **Personalize appearance and sounds** screen will pop up.
2. On the **Personalize appearance and sounds** screen, click **Display Settings**. The **Display Settings** screen will pop up.
3. On the **Display Settings** screen, click the **Monitor** tab. In the pull - down menu, select the option containing **TOSHIBA Video Dock**.
4. Uncheck the **Extend the desktop onto this monitor** box.
5. Click **OK** to close the Display Settings screen.

Windows® XP Operations:

1. Position the mouse anywhere on your computer desktop, right-click and select **Properties**. The **Display Properties** screen will pop up.
2. On the **Display Properties** screen, click the **Settings** tab. In the **Display** pull - down menu, select the option containing **TOSHIBA Video Dock**.
3. Uncheck the **Extend my windows desktop onto this monitor** box.

4. Click **OK** to close the **Display Properties** screen.



Windows Vista®



Windows® XP

(Sample Image) Display Properties screen



NOTE: Monitor “2” will also need to be configured for mirror mode in order to use three monitors in mirror mode.

Adjusting Video Settings

There are three components that make up the screen mode:

Resolution: In common usage, this refers to the number of pixels displayed on the screen horizontally and vertically.

Color Depth: This defines the number of different colors that can be shown on the screen at the same time.

Refresh rate: Measures the speed that the entire screen is rescanned. Higher frequencies reduce flicker.

Below is a list of refresh rates supported at various resolutions and color depths for the VGA and DVI component:

Resolution/ Color Depth	640x480	800x600	1024x768	1280x768	1280x960	1280x1024
16 bit	60 72 75	56 60 72 75 85	60 70 75 85	60 75 85	60 85	60 75 85
32 bit	60 72 75	56 60 72 75 85	60 70 75 85	60 75 85	60 85	60 75

The DVI-component additionally supports:

Resolution/ Color Depth	1600x1200
16 bit	60
32 bit	80

Note that interlaced modes are not supported.

Additional modes may be offered, depending upon the connected monitor, but these are not currently guaranteed.

If the monitor does not advertise the supported modes, the VGA or DVI component will choose a set of common screen modes.

If cloning the primary display, the VGA or DVI component will try to use the preferred monitor mode. In some cases, this may not be the most appropriate mode for the mirrored desktop. It is recommended that the primary display resolution be changed to closer match the default resolution of the dynadock monitor.



NOTE: For more information on supported modes, be sure to check the documentation supplied with your monitor.

Initial Use

When the VGA or DVI component first starts, it will mirror the primary monitor. Changes to the screen mode and VGA or DVI component operation mode can be made under the Windows display properties.

If no output is seen on the monitor connected to the VGA or DVI component, it may be in a mode which cannot be displayed by the monitor. This can happen if the monitor does not report its supported modes to the VGA or DVI component. Reduce the resolution of the primary display, and in turn the resolution of the VGA or DVI component display until an image is shown.



NOTE: Placing the monitor into an unsupported mode for long periods can damage it.

Adjusting the Video Settings - Windows Vista® Operations:

1. Position the mouse anywhere on your computer desktop, right-click and select **Personalize**, then click **Display Settings**.
2. To change the screen resolution or color quality, select those options on the screen. Be sure to select one of the supported resolutions and color quality numbers in the table above. For an external monitor, you can also select any resolution or color quality supported by that monitor.
3. To change the refresh rate, on the Display Settings screen, click **Advanced Settings** and then click **Monitor**.
4. Select a refresh rate from the **Screen refresh rate** pull down list. Be sure to select a refresh rate that is supported for the resolutions and color depth settings, as indicated in the table above. Then click **OK**.
5. Click **OK** to close the **Display Settings** screen.

Adjusting the Video Settings - Windows® XP Operations:

1. Position the mouse anywhere on your computer desktop, right-click and select **Properties**. The **Display Properties** screen will pop up.
2. On the **Display Properties** screen, click the **Settings** tab.
3. To change the screen resolution or color quality, select those options on the screen. Be sure to select one of the supported resolutions and color quality numbers in the table above. For an external monitor, you can also select any resolution or color quality supported by that monitor.
4. To change the refresh rate, on the Display Properties screen, click **Advanced** and then click **Monitor**.
5. Select a refresh rate from the **Screen refresh rate** pull down list. Be sure to select a refresh rate that is supported for the resolutions and color depth settings, as indicated in the table above. Then click **OK**.
6. Click **OK** to close the **Display Properties** screen.

If you use multiple dynadocks with a single computer – for example, one at work and one at home – the video settings for each dynadock are saved when you disconnect the computer. This enables you to have your dynadock at work set up for the Extended Mode while your dynadock at home is configured for Mirror Mode, and those settings will be retained each time you use the dynadock with your computer.

How Standby/Sleep or Hibernate Mode Affects Devices Attached to the dynadock™

External Monitors

The external monitor connected to the dynadock will go blank if the computer goes into Standby/Sleep or Hibernate Mode.

When in Mirror Mode, the external monitor keeps the same settings it had before the computer went into Standby/Sleep or Hibernate Mode once the computer returns to an active state

When in Extended Mode, windows that were previously on the external monitor will not move back to that secondary monitor once the computer returns to an active state

Also, if the external monitor is in Extended Mode and the computer requires a login after Standby or Hibernate Mode, the login screen appears on the primary computer monitor, not the external monitor.

Other Devices

If another device is connected to a port on the dynadock and the computer goes into Standby/Sleep or Hibernate Mode, that device will not function. For example, if you are using the Ethernet port for high-speed network access, network access will not be available until the computer returns to an active state.

Disconnecting the dynadock™

Eject Dock

When the dynadock is connected to your computer, the TOSHIBA dynadock Utility can remove all devices with one-click. Please follow these steps:

1. Right-click the icon in the system tray.
2. Select “Eject Dock” from the menu to start the eject process.



(Sample Image) Eject Dock screen

3. Wait before removing the dock from the system.

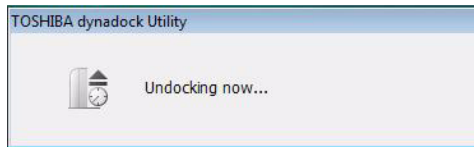

(Sample Image) Undocking screen

4. If the dock is removed from the system successfully, the icon in the system tray will disappear. Disconnect the USB cable from your computer's USB port.



CAUTION: *If the dynadock is not disconnected safely by following the above steps, or it is connected and then disconnected before it is detected by the PC, the icon will disappear too. However, it is not recommended, because it may cause loss of data and/or other damage to your PC and devices connected through the dock, especially when they are still working.*

Eject Dock and Sleep

When the dynadock is connected to your computer, the TOSHIBA dynadock Utility can remove all devices and let the system sleep instantly with one-click. Please follow these steps:

1. Right-click the icon in the system tray.
2. Select “Eject and Sleep” from the menu.



(Sample Image) Eject and Sleep screen

3. Wait before removing the dock from the system.

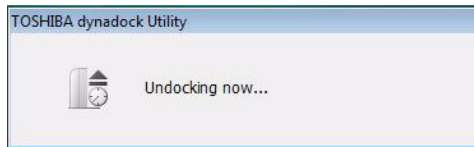

(Sample Image) Undocking screen

4. If the dock is removed from the system successfully, the icon in the system tray will disappear. Disconnect the USB cable from your computer's USB port.
5. After that, the system will go into sleep mode.



CAUTION: If the dynadock is not disconnected safely by following the above steps, or it is connected and then disconnected before it is detected by the PC, the icon will disappear too. However, it is not recommended, because it may cause loss of data and/or other damage to your PC and devices connected through the dock, especially when they are still working.

Eject by use of command line

You can run dynadock Utility by command line, please follow the steps below:

1. Click **Run...** on **Start** menu.
2. Input "C:\Program Files\TOSHIBA\dynadock Utility\TOSUSBSvrCtrl.exe" /eject, and run the program.



NOTE: C:\Program Files\TOSHIBA\dynadock Utility\ is the default directory path of your program. If you have changed the path when installing, please enter your specified path.

means "space". Please do leave a space here.

eject is the command to execute the function. There are two commands:

1. **eject:** The same function as you click "Eject Dock", please refer to [Eject Dock](#).
2. **ejectsleep:** The same function as you click "Eject and sleep", please refer to [Eject Dock and Sleep](#).

Removing Settings

TOSHIBA dynadock Utility setting program allows users to change the action of the utility function.

Opening Setting Dialog

1. Click "Start" and then click "Control panel".
2. Double-click the "TOSHIBA dynadock Utility" icon.
3. Setting dialog will appear.



NOTE: The method of opening the control panel is the same in different versions of Windows® operating system. If you can not find the "TOSHIBA dynadock Utility" icon, please click "classic view" on the left of the control panel window.

Setting Sleep Service

Sleep service allows users to decide whether to use the “Eject and Sleep” item in the system tray menu.

- Check the “Eject Dock and Sleep PC Service” box:

It allows users to execute “Eject and Sleep” from the system tray menu. Users can also select the sleep mode in the list box. There are two choices: Standby and Hibernation (for Windows® XP)/Sleep and Hibernation (for Windows Vista®).

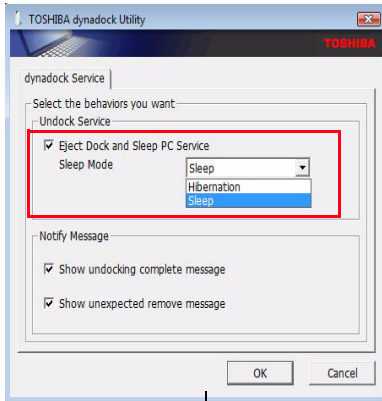

Windows Vista®

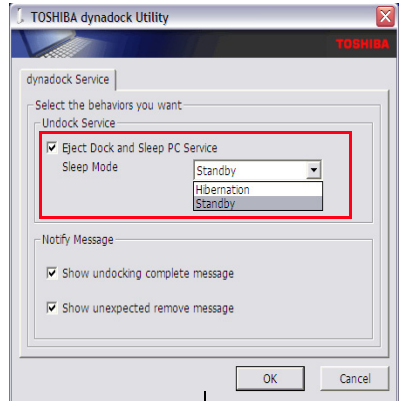

Windows® XP

(Sample Image) Undock service screen

- Uncheck the “Eject Dock and Sleep PC Service” box:

If this box is unchecked, the “Eject and Sleep” item will not be shown in the system tray menu.

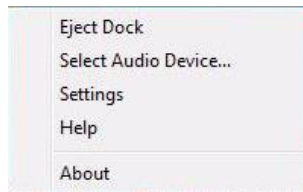

(Sample Image) Eject screen

Setting Message Notify Service

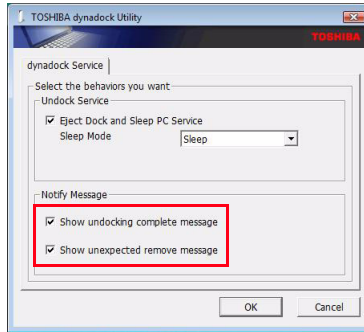

(Sample Image) Notify message service screen

- Check “Show undocking complete message” box:

If you click “Eject Dock” or “Eject Dock and Sleep”, the eject action will be executed. After the process finishes successfully, the following message prompts.

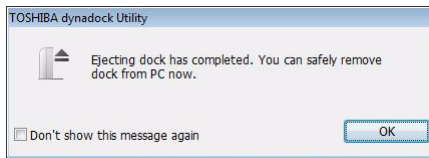

(Sample Image) Prompt message

- Uncheck “Show undocking complete message” box:
If you click “Eject Dock” or “Eject Dock and Sleep”, the eject action will be executed and finish without any prompts. In this case, it is difficult to judge whether the device has been removed safely or not.
- Check “Show unexpected remove message” box:
The utility can monitor the device changes in the system. If the dock is removed by accident, a warning will be shown.

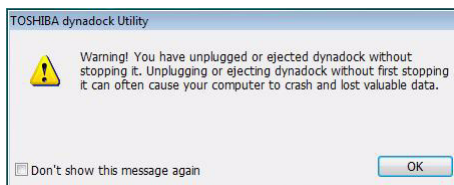

(Sample Image) Warning message

- Uncheck “Show unexpected remove message” box:
The utility will do nothing for the wrong operations, inevitable accidents or any other situations. Please make sure you are very familiar with your computer and the dock device before you uncheck this box.

Select Audio Device

When the dynadock is connected to your computer, the TOSHIBA dynadock Utility can change the default audio output device or disable/enable a selected device. Please follow these steps:

1. Right-click the icon in the system tray.
2. Select "Select Audio Device" from the menu.



(Sample Image) Select Audio Device screen

3. You may change the default device or disable/enable a selected device according to your desire.

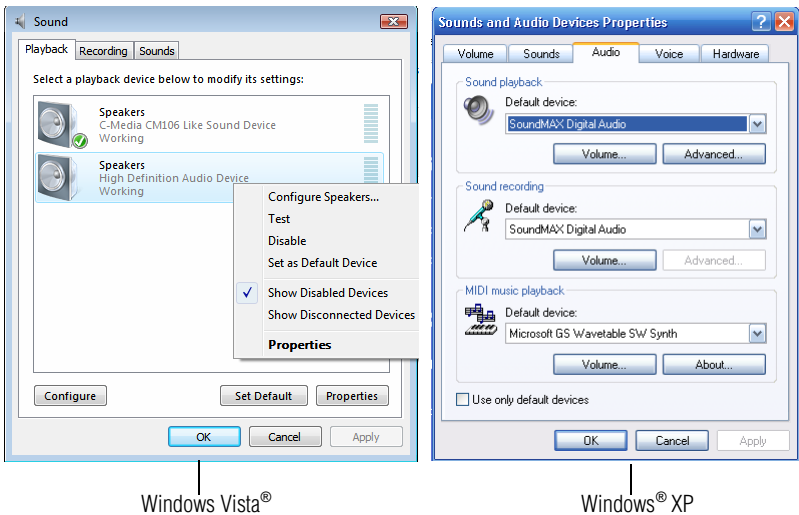

Windows Vista®

Windows® XP

(Sample Image) Change Audio Device screen

Specifications

This section summarizes the dynadock's technical specifications.

Physical Dimensions

Weight	507g/17.8 ounces (including the Base)
Size	45(w) x 78(d) x 210(h) mm/1.8" (w) x 3.1" (d) x 8.27" (h) (not including the parts that extend beyond the main body)
	114(w) x 130(d) x 223(h) mm/4.5" (w) x 5.2" (d) x 8.8" (h) (including the Base)

Environmental Requirements

Conditions	Ambient temperature	Relative humidity
Operating	5°C to 35°C (41°F to 95°F)	20% to 80%
Non-operating	-20°C to 65°C (-4°F to 149°F)	10% to 90%
Thermal Gradient	20°C per hour maximum	
Wet-bulb Temperature	26°C maximum	

Power Requirements

AC adaptor	Input: AC 100-240V
	Output: DC 5V / 5A

General Specifications

PC Interface	USB 2.0
Ports and Connectors	6 x USB 2.0 Port (Type A female connector) 1 x S/PDIF (optical digital audio output) 1 x Ethernet Port (10/100 Base-T Ethernet RJ-45 connector) 1 x Serial Port VGA x 1 (Analog D-SUB 15pin Female Connector) OR DVI-I x 1 (Digital 24-pin + Analog5-pin Female Connector) 1 x microphone (3.5 mm mono audio in) 1 x headphones or speakers(3.5 mm stereo audio out) 1 x USB 2.0 Port (Type B female Connector) 1 x DC-in plug 1 x Cable Lock Slot
Supported Video Display Modes	Windows® XP: Mirror Desktop, Extended Desktop, Primary Display
*Depending on operating system	Windows Vista®: Mirror Desktop, Extended Desktop, Primary Display
	*Some built-in video adapters may prevent a second monitor from being the primary display.

*Specifications are subject to change without further notice.

